

M900Q8

8" Qualcomm® Snapdragon™ 660 Rugged Tablet PC



KEY FEATURES

- Qualcomm® Snapdragon™ 660 (Octa-Core 2.2 GHz)
- 8" daylight readable panel with direct optical bonding
- Optional D-sub for vehicle gateway connection
- IP65 waterproof and dustproof
- Built-in NFC Module
- Integrated 1D/2D Barcode Reader (Optional)



SPECIFICATIONS

Display			
Resolution	1280x800	Size	8.0 inches
Contrast Ratio	800:1	Panel Brightness	510 nits
View Angles	85/85/85/85	Type	Projected Capacitive Multi Touch
Touch Mode	Support Hand / Gloves and Rain Mode	Bonding	Optical Bonding for Sunlight Viewability
System Specification			
Processor	Qualcomm® Snapdragon™ 660 (Octa-Core 2.2 GHz)	Memory	3GB
Storage	32GB	Operating System	Android 9.0
WLAN	802.11 a/b/g/n/ac mode	BT	BT Support
WWAN	4G/LTE (Optional)	GNSS	GPS/AGPS
RFID	Default NFC (Read / Write, Peer to Peer mode)	Sensors	Ambient Light Sensor, E-Compass, Gyro, Acceleration Sensors, Automatic Screen Rotation
Camera			
Front Camera	8MP Camera	Rear Camera	13MP Camera with LED Auxiliary Light (Auto Focus)
Mechanical			
Dimension	226.57 x 147.82 x 21.5 mm	Weight	900g
IO Ports			
USB Port	1 x USB 2.0 Type A 1 x USB 3.0 Type C OTG	SD Card Slot	1 x Micro SD Card Slot
SIM Card Slot	1 x SIM Card Slot	Audio	1 x Audio Combo connector (Mic in or Line Out) 1 x Built-in Mic 1 x Speaker
Expansion Port	1 x 15-pin D-Sub Connector for Power Input, USB 2.0, Audio Out, and Tx/ Rx	Indicator	2 x LED Indicators (Power, Charging)
Docking Connector	1 x Docking Connector		
Environment			
Operating Humidity	10% to 90% RH, Non-Condensing	Operating Temperature	-10°C to 50°C (Battery mode)
Storage Temperature	-30°C to 70°C	Shock	MIL-STD-810G Method 516.6 Procedure I
Vibration	MIL-STD-810G Method 514.6 Procedure I	IP rating	IP65 Certified, Waterproof and Dustproof

Drop	MIL-STD-810G Method 516.6, 5 ft		
Control			
Button	1 x Power Button, 1 x Home Button, 3 x Function button		
Power			
Battery	7.6V 4200 mAh	Battery Operating Time	10Hr
Power Rating	19V	Adapter	19V 3.42A Adapter
Accessory			
Accessory	Adapter and Power Cord Standard Battery Pack	Optional Accessory	Desk Dock Vehicle Gateway Vehicle Cradle Vehicle Charger Battery Charger Hand Strap Capacitive Stylus

Barcode Scanner			
Barcode Scanner	1D/2D Barcode Reader (Optional)		

DIMENSIONS UNIT:MM

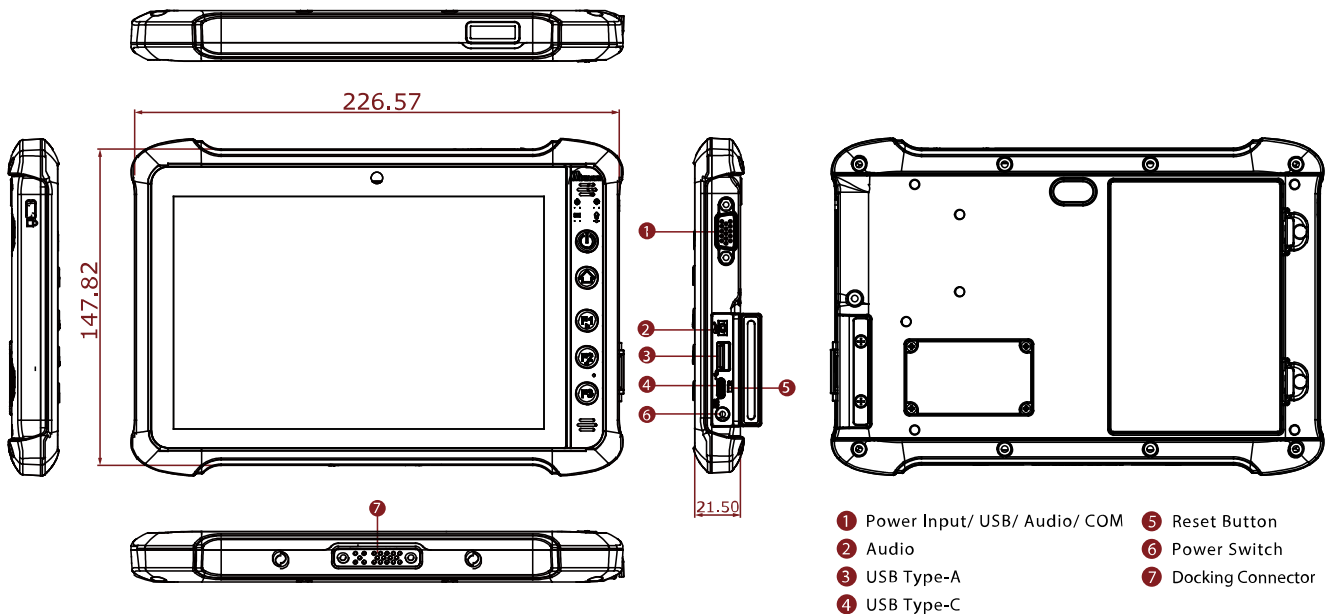

NOTE

1. Measured at dimming LCD brightness. Varies depending on the usage conditions, or when an external device is attached.
2. Total usable memory will be less dependent upon actual system configuration.
3. Barcode Reader and NFC Scanner are mutually exclusive options.
4. Length measurements do not include protrusions. Weight varies with options.
5. Accessories and Integrated options may vary depending on your configuration.
6. This is a simplified drawing and some components are not marked in detail.
7. The product shown in this datasheet is a standard model. For diagrams that contain customized or optional I/O, please contact the Winmate Sales Team for more information.